

# Ceiling Diffusers

Type DLQ · ADLQ

recommended for room heights  
from 2.60 . . . 4.00 m



**TROX<sup>®</sup> TECHNIK**

TROX GmbH  
Heinrich-Trox-Platz  
D-47504 Neukirchen-Vluyn

Telephone +49/28 45/2 02-0  
Telefax +49/28 45/2 02-2 65  
e-mail [trox@trox.de](mailto:trox@trox.de)  
[www.troxtechnik.com](http://www.troxtechnik.com)

# Contents · Description

Description .....	2
Construction · Dimensions .....	3
Installation · Mounting Details .....	4
Materials .....	4
Nomenclature .....	5
Spectral Data .....	5
Acoustic Data .....	6
Aerodynamic Data .....	8
Order Details .....	10

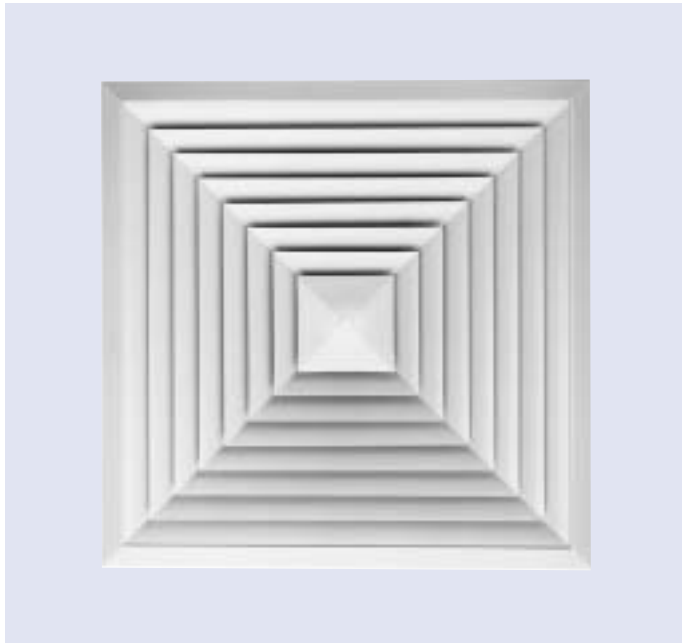

## Description

Square ceiling diffusers type DLQ (steel) and ADLQ (aluminium) are ideal for flush mounting in ceilings. They are suitable for use in rooms with heights up to 4.00 m. The recommended supply air temperature differential is  $\pm 10\text{K}$ . Ceiling diffusers can be used both for supply and extract applications.

With a fixed blade arrangement the ceiling diffusers are mainly suitable for horizontal discharge.

Specially developed ancillaries and plenum boxes, with optional flow rate control dampers, are available to ensure optimum discharge characteristics.

# Construction · Dimensions

## Construction

The face section of the type DLQ and ADLQ diffuser consists of a peripheral border, fixed air control blades and a centre cone. The diffuser face section is fitted or removed by means of a central fixing screw. The screw head is then covered with a decorative cap.

Types DLQ and ADLQ are available as a diffuser face complete with plenum box and side entry spigot, or with the following ancillaries:

Size	D	H	K	Q <sub>1</sub>	Q <sub>2</sub>	AK Code
250	158	262	216	248	198	AK 008
300	158	262	266	298	248	AK 009
400	198	307	372	398	348	AK 002
500	248	357	476	498	448	AK 010
600	313	420	567	598	548	AK 011
625	313	420	567	623	573	AK 011

- ...-AR with rear mounting ring
- ...-AG with opposed blade volume control damper adjustable from diffuser face (not available for (size 250))
- ...-C with double flap damper adjustable from diffuser face

The use of versatile ancillaries such as standard or duct mounting subframes for installation in vertical ducts, results in great flexibility in installation for this type of diffuser. For easy adjustment of volume flow rate the plenum box is equipped, if required, with a test point for measuring pressure and a volume control damper which can be adjusted by a cord. The calibration curve is enclosed with each plenum box.

The plenum box with side entry spigot can be used with various Trox air diffusers providing the combined technical data is taken into account.

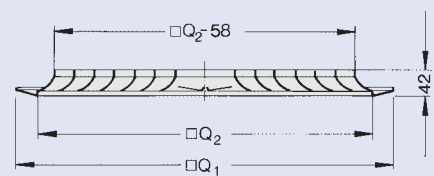
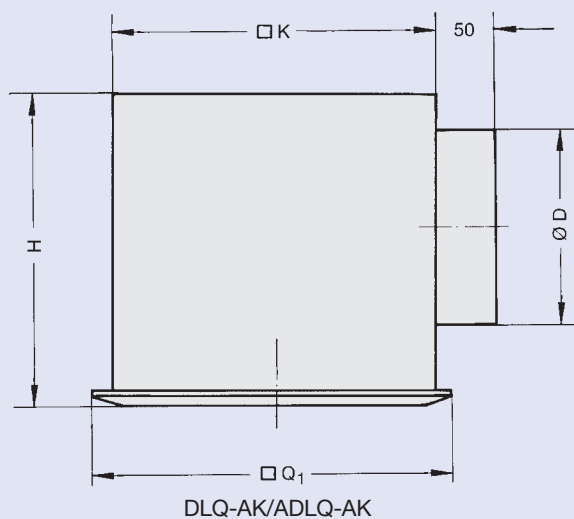

DLQ-A/ADLQ-A

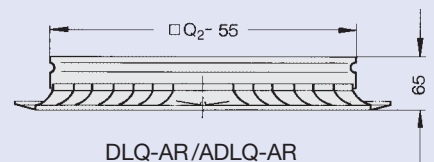

DLQ-AR/ADLQ-AR

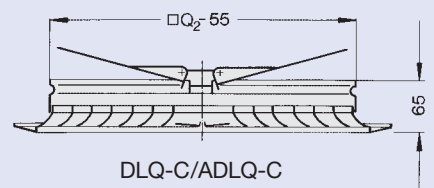

DLQ-C/ADLQ-C



DLQ-AG/ADLQ-AG

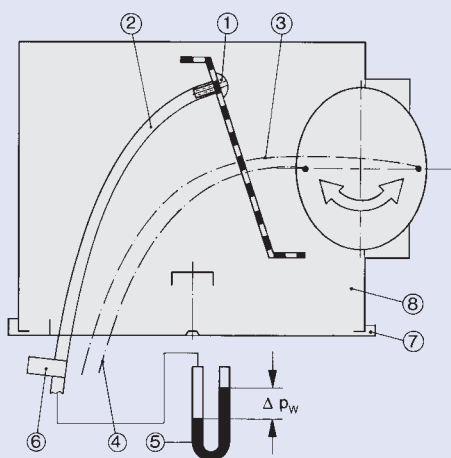

- ① Measurement test point
- ② Plastic tubing
- ③ White cord: damper open
- ④ Green cord: damper closed
- ⑤ Manometer (by others)
- ⑥ Code
- ⑦ Diffuser face
- ⑧ Plenum box

# Installation · Assembly · Materials

## Installation · Assembly

Type DLQ or ADLQ ceiling diffusers can be adapted for use in almost all situations using the accessories available. All sizes are suitable for mounting flush with the ceiling.

The plenum box is suspended on wire or straps using the holes provided. The seal provided must be fixed to the edging of the plenum box on site by others.

The diffuser face is fixed to the plenum box by the centre screw and the cross bridge provided.

If a vertical rigid duct is provided on site the diffuser can be fixed by means of a cross bridge and centre screw, or directly to the neck of the diffuser, e.g., by self-tapping screws. For these types of fixing the AR can be used. A duct mounting subframe can be supplied for constructions without plenum boxes. The following examples show the various types of installation.

## Materials DLQ

The diffuser face and rear-mounted ancillaries are in deep drawn or formed sheet steel.

The face of the diffuser is pre-treated and powder coated in pure white (RAL 9010). The surface of the rear components are phosphate treated and stove enamelled black using an electro-dipping process.

Plenum box of galvanised sheet steel, rubber spigot lip seal.

## Materials ADLQ

The diffuser face is in extruded aluminium sections, natural anodised E6-C-0. The rear ancillaries are in formed sheet steel. The surfaces are phosphate treated and black stove-enamelled (RAL 9005).

Plenum box of galvanised sheet steel, rubber spigot lip seal.

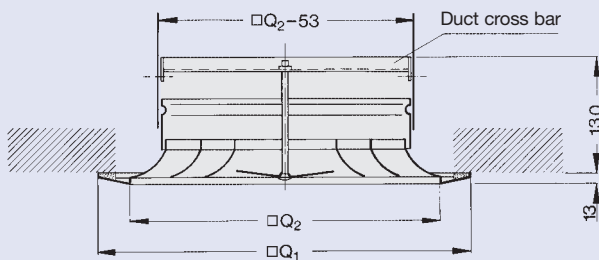

Installation with duct cross bar  
Recommended damper: ... - C

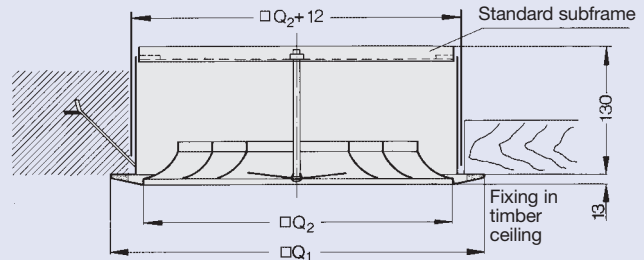

Installation with standard subframe  
Recommended dampers: ... - AG and ... - C

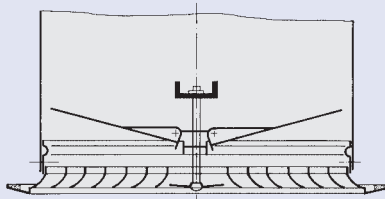

Damper with duct cross bar installed  
in a vertical duct

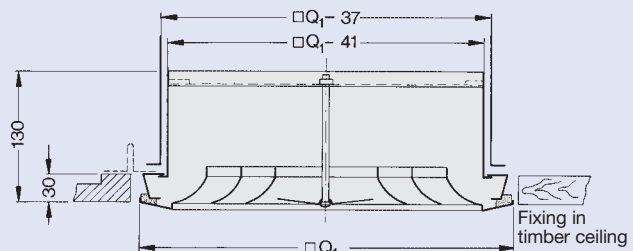

Mounting with special subframe  
Recommended dampers: ... - AG and ... - C

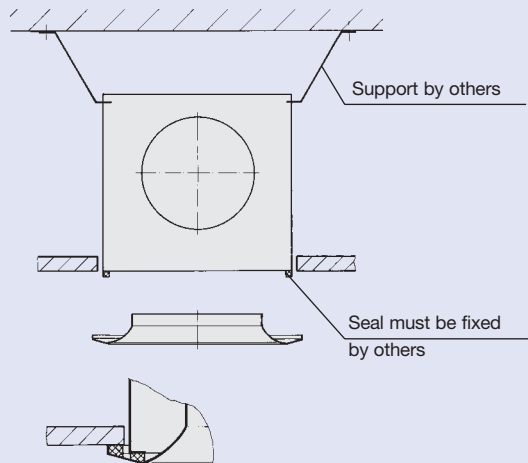

Installation of diffuser face into an AK

# Nomenclature · Spectral Data

## Nomenclature

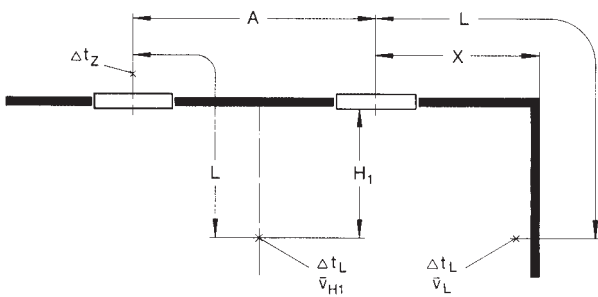

- $\dot{V}$  in l/s: Volume flow per diffuser
- $\dot{V}$  in m<sup>3</sup>/h: Volume flow per diffuser
- $A$  in m: Spacing between two diffusers
- $L$  in m: Horizontal plus vertical distance ( $X + H_1$ ) discharge to the wall
- $X$  in m: Distance between centre of diffuser and the wall

- $H_1$  in m: Distance between ceiling and occupied zone
- $A_{\text{eff}}$  in m<sup>2</sup>: Effective outlet area
- $\bar{v}_L$  in m/s: Time average air velocity at the wall
- $\bar{v}_{H_1}$  in m/s: Time average air velocity between two diffusers at distance  $H_1$  from the ceiling
- $\Delta t_z$  in K: Temperature difference between supply and room air
- $\Delta t_L$  in K: Difference between core and room temperature at distance  $L = A/2 + H_1$  or  $L = X + H_1$
- $\Delta p_t$  in Pa: Total pressure drop
- $L_{WA}$  in dB(A): A-weighted sound power level
- $L_{WNC}$ : NC rating of sound power level
- $L_{WNR}$ :  $L_{WNR} = L_{WNC} + 2$
- $L_{pA}, L_{pNC}$ : A-weighting or NC rating of room sound pressure level  
 $L_{pA} \approx L_{WA} - 8 \text{ dB}$   
 $L_{pNC} \approx L_{WNC} - 8 \text{ dB}$
- $\Delta L$  in dB/Oct.: Relative level with respect to  $L_{WA}$
- $L_W$  in dB/Oct.: Octave band sound power level of regenerated noise  $L_W = L_{WA} + \Delta L$

Relative spectra  $\Delta L$  for damper angle 0°

Type	Size	Effective air discharge velocity $v_{\text{eff}}$ m/s	Octave band centre frequency in Hz									
			63	125	250	500	1000	2000	4000	8000		
DLQ/ADLQ-A	250	3	9	2	3	1	-12	-26	-31	-35		
	300	4	9	3	2	0	-7	-19	-28	-30		
	400	5	7	2	1	-2	-4	-15	-26	-29		
	500	6	5	0	-2	-4	-3	-12	-26	-29		
	600	6	5	0	-2	-4	-3	-12	-26	-29		
DLQ/ADLQ-C	250	3	3	2	3	1	-11	-27	-35	-38		
		4	6	3	2	0	-7	-20	-31	-34		
		5	7	3	1	-1	-5	-15	-28	-31		
		6	8	2	-1	-2	-3	-12	-26	-30		
	600	3	6	-1	2	0	-8	-20	-27	-32		
		4	8	-1	1	-1	-4	-14	-23	-26		
		5	9	-2	-2	-3	-3	-10	-22	-26		
		6	8	-4	-5	-5	-3	-8	-21	-25		
		DLQ/ADLQ-AG	300	3	10	2	3	0	-10	-26	-31	-35
			400	4	8	2	2	0	-6	-19	-27	-30
DLQ/ADLQ-AG	500	5	5	1	0	-2	-4	-14	-24	-28		
	600	5	5	1	0	-2	-4	-14	-24	-28		
	625	6	3	0	-2	-4	-3	-11	-23	-26		

relative spectra for DLQ-... / ADLQ-AK available on request

# Acoustic Data

## Example

Data given:  
DLQ-A/500

Volume flow per diffuser  $\dot{V} = 300 \text{ l/s}$

Required: Octave sound power level of regenerated noise  $L_w$

Diagram 3: Sound power level and pressure drop

$L_{WA} = 30 \text{ dB(A)}$

$\Delta p_t = 11 \text{ Pa}$

$$v_{\text{eff}} = \frac{300}{0.0675 \cdot 1000} = 4.4 \text{ m/s}$$

Octave band centre frequency in Hz	63	125	250	500	1000	2000	4000	8000
$L_{WA}$ in dB(A)	30	30	30	30	30	30	30	30
$L$ in dB(A)	+9	+3	+2	0	-7	-19	-28	-30
$L_w$ in dB	39	33	32	30	23	11	2	0

1 Sound power level and pressure drop  
Type DLQ/ADLQ-AK (supply air)

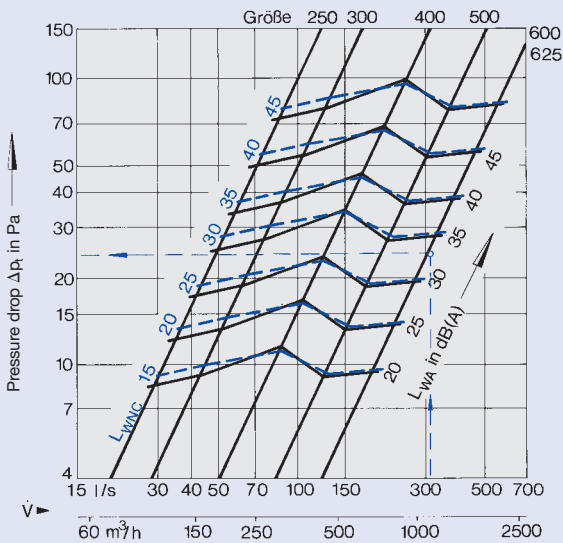

2 Sound power level and pressure drop  
Type DLQ/ADLQ-AK (extract air)

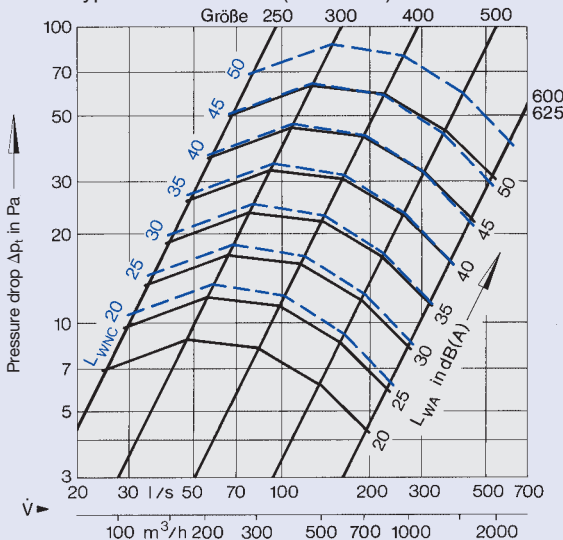

Correction to Diagram 1: Damper setting

Size	Damper angle	0°	45°	90°
250	$\Delta p_t$	x 1.0	x 1.2	x 2.4
	$L_{WA}$	-	+1	+2
	$L_{WNC}$	-	+1	+2
300	$\Delta p_t$	x 1.0	x 1.5	x 3.5
	$L_{WA}$	-	+3	+9
	$L_{WNC}$	-	+3	+9
400	$\Delta p_t$	x 1.0	x 1.6	x 2.8
	$L_{WA}$	-	+6	+16
	$L_{WNC}$	-	+6	+16
500	$\Delta p_t$	x 1.0	x 1.6	x 5.0
	$L_{WA}$	-	+5	+13
	$L_{WNC}$	-	+5	+13
600/625	$\Delta p_t$	x 1.0	x 1.5	x 4.7
	$L_{WA}$	-	+6	+14
	$L_{WNC}$	-	+6	+14

Correction to Diagram 2: Damper setting

Size	Damper angle	0°	45°	90°
250	$\Delta p_t$	x 1.0	x 1.1	x 1.7
	$L_{WA}$	-	-	+1
	$L_{WNC}$	-	-	-
300	$\Delta p_t$	x 1.0	x 1.2	x 1.9
	$L_{WA}$	-	+2	+4
	$L_{WNC}$	-	+2	+4
400	$\Delta p_t$	x 1.0	x 1.3	x 2.6
	$L_{WA}$	-	+1	+4
	$L_{WNC}$	-	-	+3
500	$\Delta p_t$	x 1.0	x 1.5	x 3.6
	$L_{WA}$	-	+1	+6
	$L_{WNC}$	-	+1	+5
600	$\Delta p_t$	x 1.0	x 1.8	x 4.1
	$L_{WA}$	-	+1	+7
	$L_{WNC}$	-	-	+5
625	$\Delta p_t$	x 1.0	x 1.9	x 4.1
	$L_{WA}$	-3	-1	+4
	$L_{WNC}$	-3	-3	+3

### Correction for DLQ/ADLQ-C, Diagram 4

Size		Damper opening		
		100 %	50 %	25 %
250	$\Delta p_t$	x 1.0	x 4.3	x 9.8
	$L_{WA}$	-	+ 24	+ 36
	$L_{WNC}$	-	+ 24	+ 37
300	$\Delta p_t$	x 1.0	x 2.8	x 7.7
	$L_{WA}$	-	+ 17	+ 33
	$L_{WNC}$	-	+ 17	+ 35
400	$\Delta p_t$	x 1.0	x 3.1	x 12.4
	$L_{WA}$	-	+ 18	+ 40
	$L_{WNC}$	-	+ 18	+ 43
500	$\Delta p_t$	x 1.0	x 3.6	x 18.0
	$L_{WA}$	-	+ 18	+ 45
	$L_{WNC}$	-	+ 19	+ 50
600	$\Delta p_t$	x 1.0	x 1.9	x 5.5
	$L_{WA}$	-	+ 11	+ 30
	$L_{WNC}$	-	+ 9	+ 30
625	$\Delta p_t$	x 1.1	x 2.4	x 13.7
	$L_{WA}$	+ 1	+ 18	+ 47
	$L_{WNC}$	+ 2	+ 16	+ 49

### Correction for DLQ/ADLQ-AG, Diagram 5

Size		Damper opening		
		100 %	50 %	25 %
300	$\Delta p_t$	x 1.0	x 2.3	x 7.1
	$L_{WA}$	-	+ 17	+ 34
	$L_{WNC}$	-	+ 17	+ 38
400	$\Delta p_t$	x 1.0	x 3.1	x 10.9
	$L_{WA}$	-	+ 21	+ 39
	$L_{WNC}$	-	+ 22	+ 43
500	$\Delta p_t$	x 1.0	x 4.0	x 13.5
	$L_{WA}$	-	+ 24	+ 42
	$L_{WNC}$	-	+ 25	+ 47
600	$\Delta p_t$	x 1.0	x 3.5	x 14.4
	$L_{WA}$	-	+ 23	+ 45
	$L_{WNC}$	-	+ 25	+ 50
625	$\Delta p_t$	x 1.0	x 3.5	x 17.4
	$L_{WA}$	-	+ 24	+ 47
	$L_{WNC}$	-	+ 26	+ 52

### 3 Sound power level and pressure drop Type DLQ/ADLQ-A

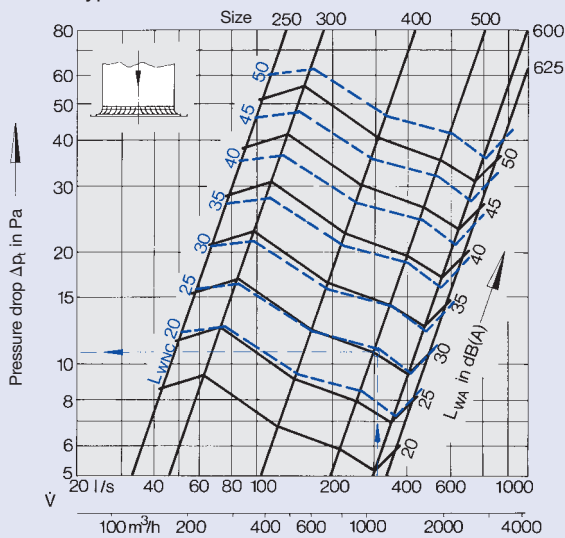

### 4 Sound power level and pressure drop Type DLQ/ADLQ-C

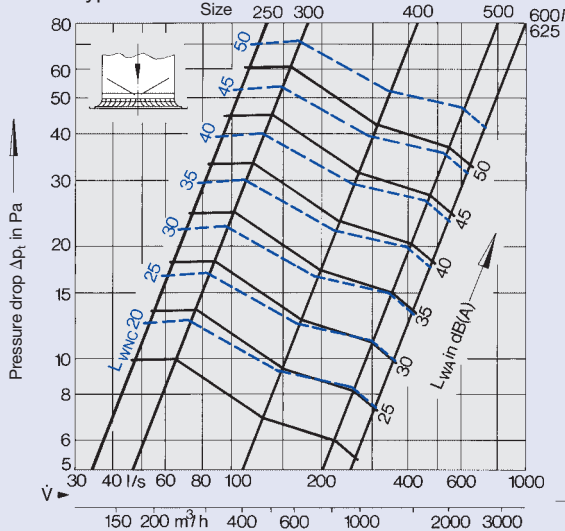

### 5 Sound power level and pressure drop Type DLQ/ADLQ-AG

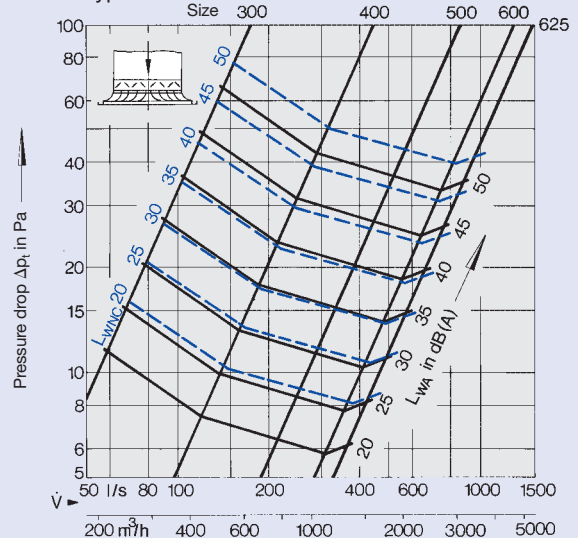

# Aerodynamic Data

## Example

Data given:  
DLQ-AK/600

Volume flow per diffuser

Supply air temp. difference

Spacing between two diffusers

Distance between ceiling and occupied zone

Distance between centre of diffuser and the wall

Throw towards wall, horizontal plus vertical distance

$$\dot{V} = 300 \text{ l/s}$$

$$\Delta t_z = -6 \text{ K}$$

$$A = 6.50 \text{ m}$$

$$H_1 = 1.20 \text{ m}$$

$$X = 4 \text{ m}$$

$$L = 5.2 \text{ m}$$

Diagram 1: Sound power level and pressure drop

$$L_{WA} = 33 \text{ dB(A)} \quad (L_{WNC} = 28 \text{ NC})$$

$$\Delta p_t = 24 \text{ Pa}$$

Diagram 6:

$$L = A/2 + H_1$$

$$L = 3.25 + 1.20 = 4.45 \text{ m}$$

$$\Delta t_L / \Delta t_z = 0.15$$

$$\Delta t_L = -6 \cdot 0.15 = -0.9 \text{ K}$$

$$L = 5.20 \text{ m}$$

$$\Delta t_L / \Delta t_z = 0.11$$

$$\Delta t_L = -6 \cdot 0.11 = -0.66 \text{ K}$$

Temperature quotient

between two diffusers

at the wall

Diagram 11:

$$\bar{v}_{H1} = 0.12 \text{ m/s}$$

$$\bar{v}_L = 0.22 \text{ m/s}$$

Air velocity

between two diffusers

at the wall

6 Temperature Quotient

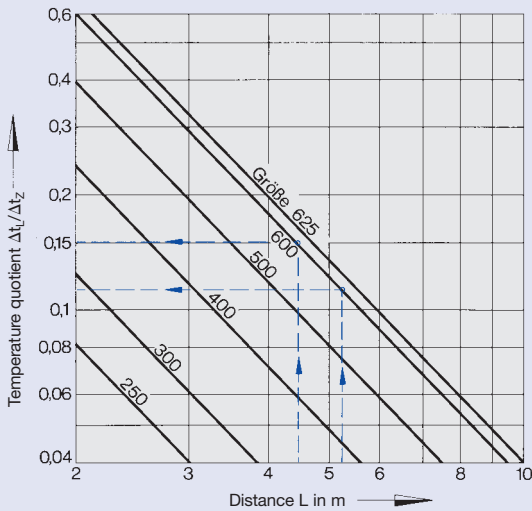

Effective outlet area

Size	250	300	400	500	600	625
$A_{\text{eff}}$ in $\text{m}^2$	0.0095	0.0175	0.0370	0.0675	0.1100	0.1230

7 Air velocity

Size 250

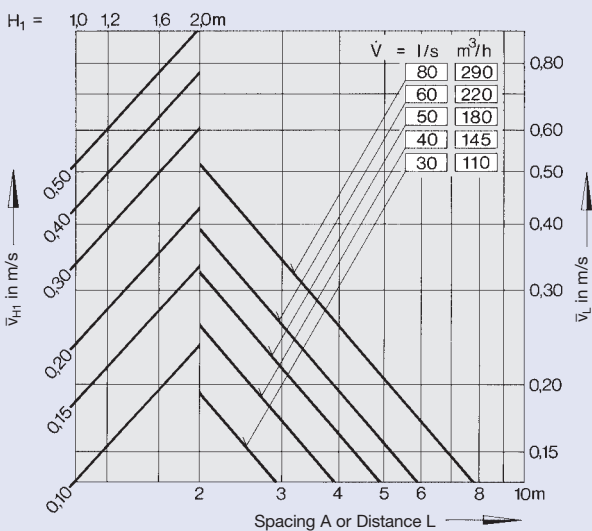

8 Air velocity

Size 300

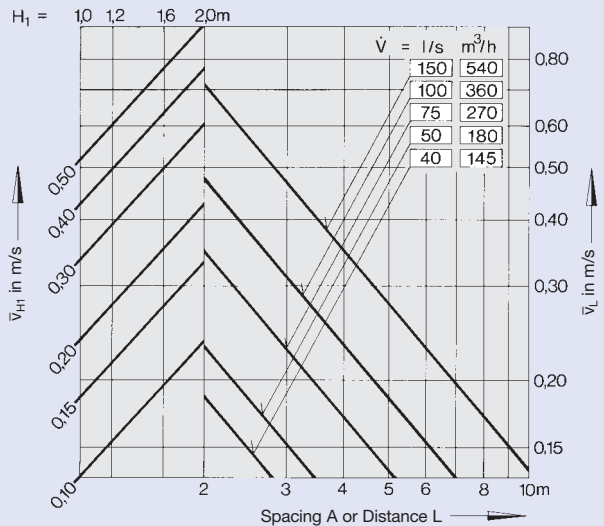

# Aerodynamic Data

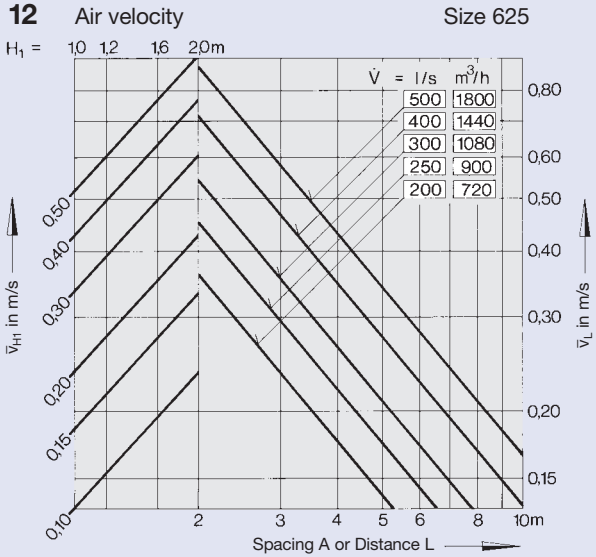
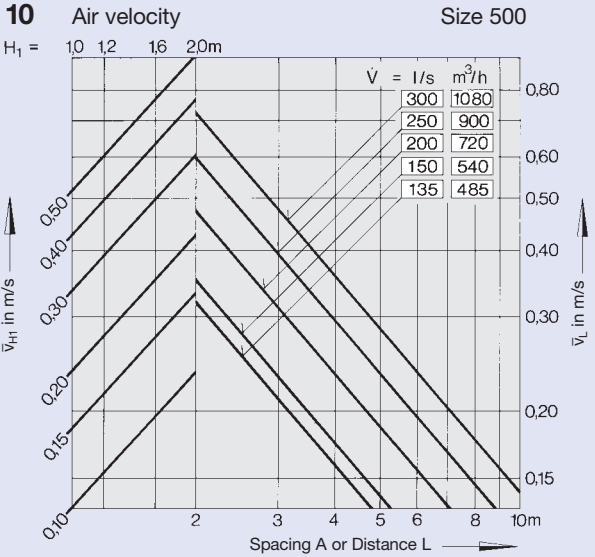
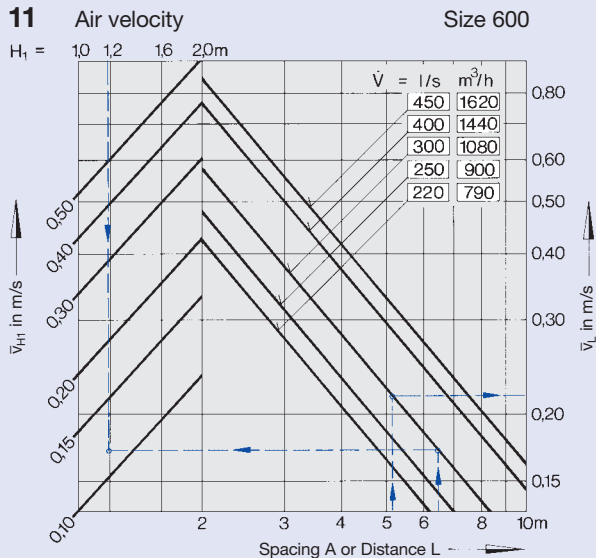
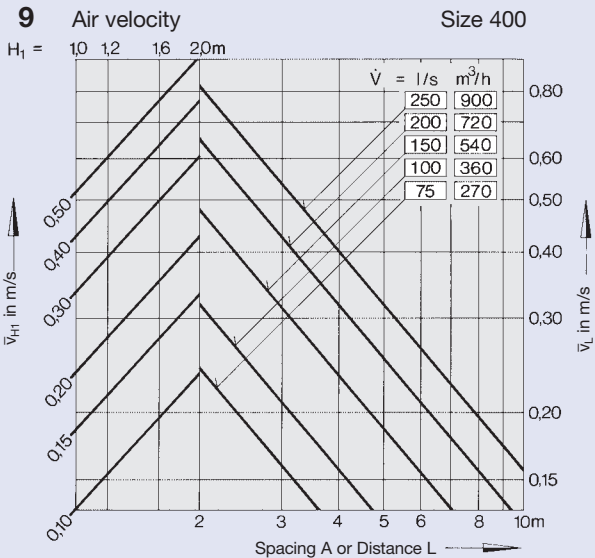

# Order Details

## Specification Text

Square ceiling diffuser for flush mounting, suitable for horizontal discharge, comprising diffuser face with mitred perimeter border, border has rear sealing strip, fixed air control blades, central fixing screw with decorative cap. Optional ancillaries: rear mounting ring, opposed blade damper adjustable from the front face, double flap damper adjustable from the front face; (alternatively with spigot damper and/or lip seal and test point for measuring pressure). The plenum box also has holes for suspending the assembly from the ceiling slab.

The plenum boxes with side entry circular spigots can be combined with various TROX diffusers providing technical data for the combination is taken into consideration.

### Materials DLQ

The diffuser face and rear accessories are in deep drawn or formed sheet steel.

The surface of the diffuser face is pre-treated and powder coated pure white (RAL 9010). The surfaces of the rear components are phosphate treated and stove enamelled black (RAL 9005) using an electro-dipping process.

Plenum box in galvanised sheet metal, rubber lip seal.

### Materials ADLQ

The diffuser face is in extruded aluminium sections, natural anodised E6-C-0, rear ancillaries in formed sheet steel, surfaces phosphate treated and stove-enamelled using an electro-dipcoat process, black (RAL 9005), finish resistant to saturated environment for a minimum of 100 hours without deterioration (DIN 50 017).

Plenum box in galvanised sheet metal, rubber lip seal.

## Order code

These codes do not need to be completed for standard products

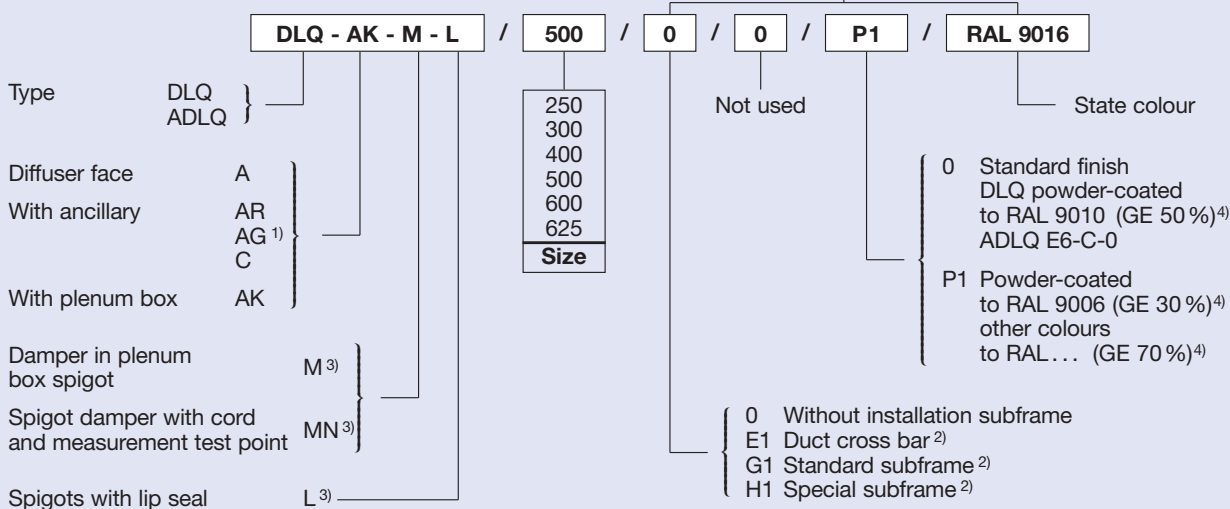

1) Not available for size 250

2) Only for types ...-A, ...-AG and ...-C

3) Only for construction ...-AK

4) GE = Gloss level

## Order Example

Make: TROX  
Type: DLQ - AK - M - L / 500 / P1 / RAL 9016